

NOTE: BREAK ALL CORNERS WITH 0.015" (.38 MM) RADIUS UNLESS OTHERWISE NOTED. STANDARD TOLERANCES TO APPLY UNLESS OTHERWISE SPECIFIED.

CUSTOMER	CAN ART STD.	DIE No.	ES05803	REV. No.	1
DESCRIPTION	3" x 2" x 3/16" ANGLE	CUSTOMER PART No.		PROPOSAL No.	S-14797

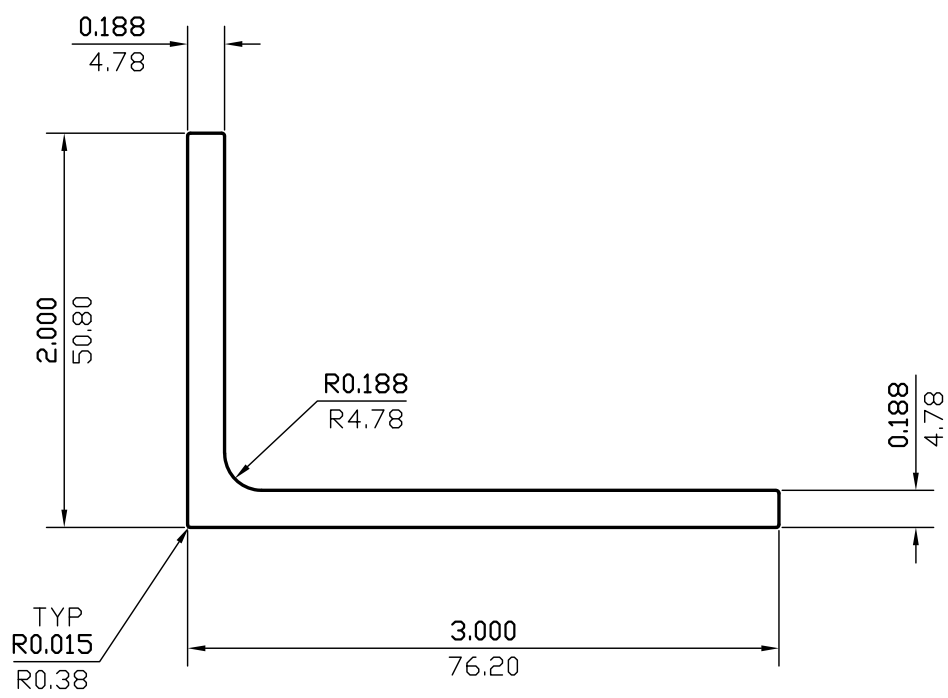

WALL THICKNESS 0.188 (4.78) EXCEPT AS SHOWN

DATE	REV	DESCRIPTION	BY					
03/20/23	1	REMOVED ALLOY	JASON					
EST. AREA	0.912	IN. ²	EST. AREA	588.390	MM. ²			
EST. WT.	1.076	LBS/FT.	EST. WT.	1.602	KG/M.			
EST. PER.	9.887	IN.	EST. PER.	251.133	MM.			
OUT PER.		IN.	OUT PER.		MM.			
C.C.D.	3.593	IN.	C.C.D.	91.272	MM.			
FINISH	M/F		ALLOY					
CKD BY	FACTOR	9	SCALE	1:1	DWN BY	P.M.	DATE	07/06/2004

CAN ART

85 PARKSHORE DRIVE
BRAMPTON, ONT L6T 5M1
TEL. NO. (905) 791-1464
FAX NO. (905) 791-9151
WEB: www.canart.com

ALUMINUM EXTRUSION INC.

THIS DRAWING IS NOT NECESSARILY A COPY OF YOUR ORIGINAL. PLEASE APPROVE DIMENSIONS AND TOLERANCES INDICATED. CAN ART ASSUMES NO RESPONSIBILITY EITHER TECHNICAL OR LEGAL FOR HAVING THIS SHAPE MADE. THE CUSTOMER AGREES TO FULLY PROTECT CAN ART ALUMINUM FROM CLAIMS OF OTHERS RESULTING FROM THIS SHAPE.

SIGNED: _____ DATE: _____